

Mathematics, Grade 9

G1B9

The lengths of the sides of one triangle are 8 inches, 10 inches, and 12 inches. What is the perimeter in inches of a similar triangle whose shortest side is 4 inches?

- A. 10
- B. 12
- C. 15
- D. 30

G1A9

Which of the following pairs of angles are complementary?

- A. 24° and 66°
- B. 56° and 124°
- C. 24° and 66° ; 34° and 56°
- D. 56° and 124° ; 66° and 114°

A2A9

The figure shows the first 3 stages of a pattern whose components are squares. What is the area (in square units) of the 10th stage?



- A. 15
- B. 17
- C. 19
- D. 21

A4A9

An engineer designs a road that rises 2 feet for every 50 feet of horizontal distance it covers. What is the grade (slope) of this road?

- A. 2%
- B. 4%
- C. 25%
- D. 48%

A3A9

The objects on each side of the balance have exactly the same total mass.

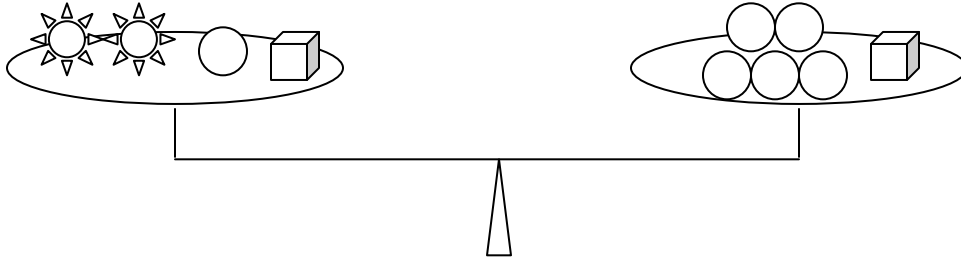

Which does the  balance?

A. 

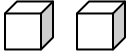
B. 

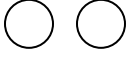
C. 

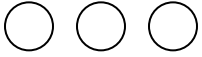
D. 

Use the figure below to answer question.

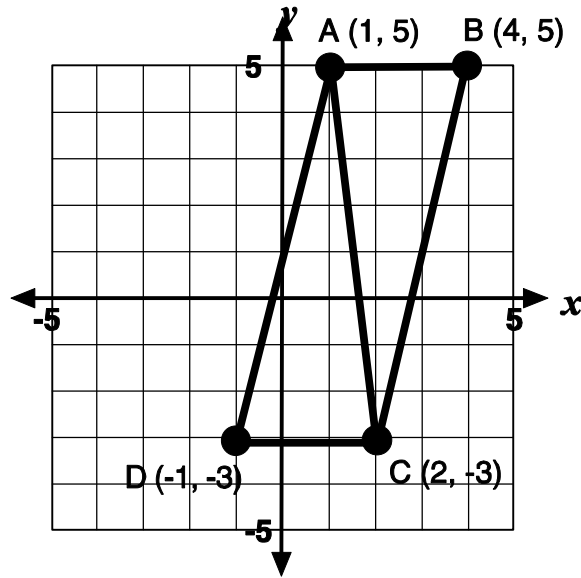

G2A9

Given the vertices of parallelogram $ABCD$ in this standard (x, y) coordinate plane, what is the area of $\triangle ABC$ in square units?

- A. 10
- B. 12
- C. 15
- D. 16

G4B9

On this figure, the distance from Lewis to Clark is 90 miles. What is the distance from Lewis to Pacifica in miles? [Sheila will have to fix graphic.]

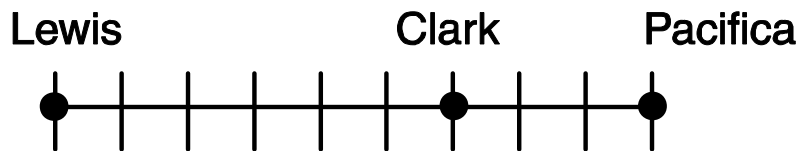

- A. 45
- B. 105
- C. 135
- D. 150

G1A9

The legs of a right triangle measure 20 centimeters and 21 centimeters. How long is the hypotenuse in centimeters?

- A. 22
- B. 25
- C. 29
- D. 35

A1D9

Which is the y -intercept for the function $f(x) = 3x - 6$?

- A. $(0, -6)$
- B. $(-6, 0)$
- C. $(0, 2)$
- D. $(2, 0)$

G1A9

Which two angle measurements (in degrees) are complementary?

- A. 33 and 47
- B. 42 and 48
- C. 51 and 69
- D. 63 and 37

A4A9

Chris drove from Blue Springs (a city 20 miles from the Kansas state line) to Marshall Junction (a location 57 miles from the Kansas state line) in 32 minutes at a constant speed. The speed limit is 70 mph. Did Chris break the speed limit? Support your answer.

Yes _____ No _____

A2D9

Two of your classmates are discussing these equations:

$$y = 2x + 7 \text{ and } g = x - 3$$

Jon claims that y will *always* be greater than g because you multiply by 2 and add 7 rather than subtract 3. Jon supports his claim with this table and graph:

Equation numbers

x	y	g
0	7	-3
1	9	-2
2	11	-1
3	13	0
4	15	1

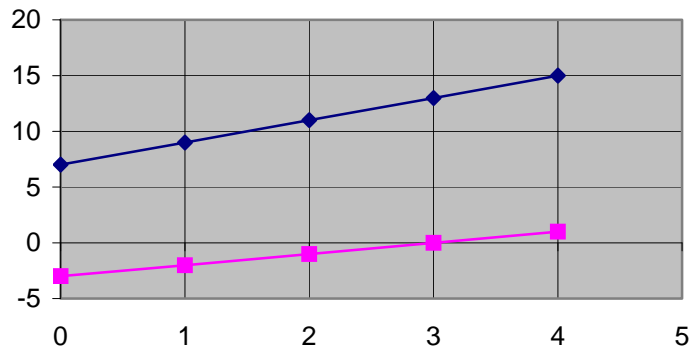

Do you agree or disagree with Jon? Show your work or describe how you got your answer.

Agree: _____ Disagree: _____

A1D9

Look at this series of figures and the table.

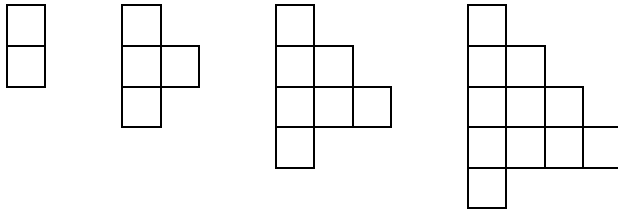

Figure Number	1	2	3	4
Perimeter	6	10	14	18
Area	2	4	7	11

Sammy believes that the perimeter will always be greater than the area. Julie thinks that the area will become greater than the perimeter before the 10th figure. With which student do you agree? Justify your answer.

A1E9

When velocity is constant, distance traveled, d , is given by the formula $d = vt$, where v equals velocity and t equals time. What is the effect on velocity if twice the distance is traveled in half the time? Explain your answer.

A2A9

Write and explain an expression that describes this pattern:

$$\frac{3}{4}, \frac{9}{8}, \frac{27}{16}, \frac{81}{32}, \dots$$

Expression: _____

G2C9

After a piece of property your parents want to buy was surveyed, they discovered that the land is in the shape of a trapezoid:

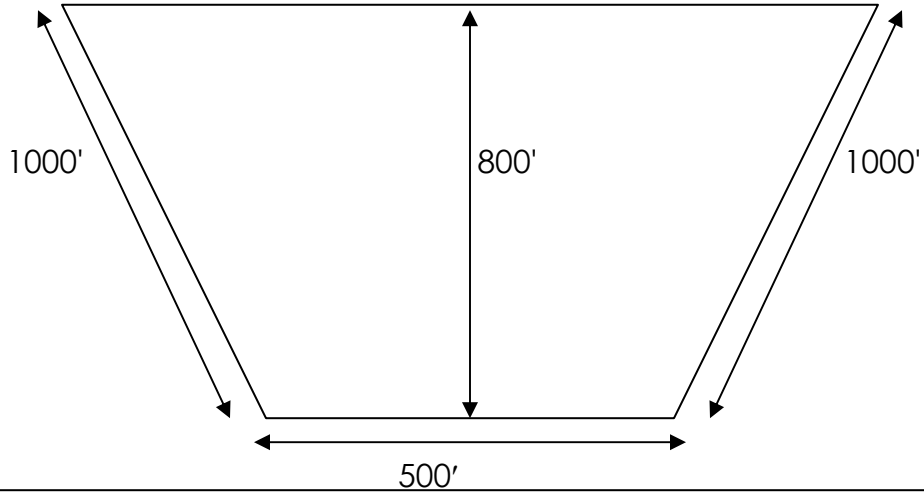

Calculate the number of acres in this plot of land. An acre contains 43,560 square feet. Provide the work that shows how you arrived at your answer and write your answer on the line.

_____ Acres

G2A9

Find the straight-line distance from the store to the school. Round your answer to the nearest hundredth of a mile. Provide the work that shows how you arrived at your answer and write your answer on the line.

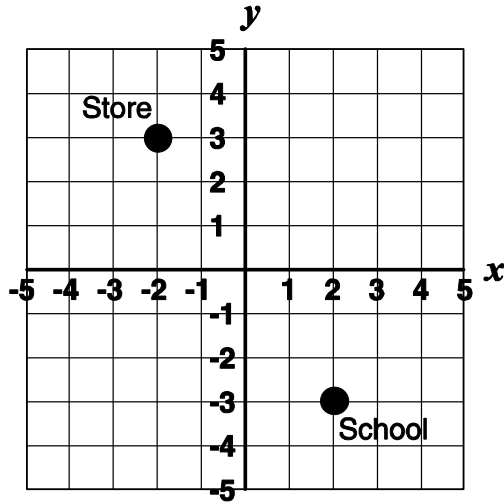

Each block grid = 0.75 mile

_____ Miles

G1B9

Building codes for Smallville state that no building may be more than 35 feet tall. A carpenter constructing the building in the figure would like to build the roof so that the vertical rise of its two inclines will be 10 inches for every foot of horizontal distance as they extend toward the peak of the house.

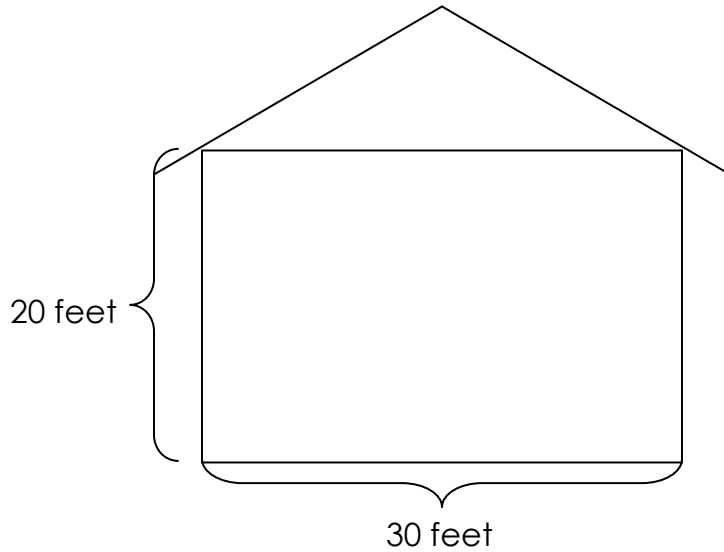

Given the other dimensions shown, will the carpenter be able to build the roof the way he wants to and still meet the code? Show work that supports your conclusion.

G1B9

A carpenter constructing the building in the figure would like to build the roof so that the vertical rise of its two inclines will be 10 inches for every foot of horizontal distance as they extend toward the peak of the house.

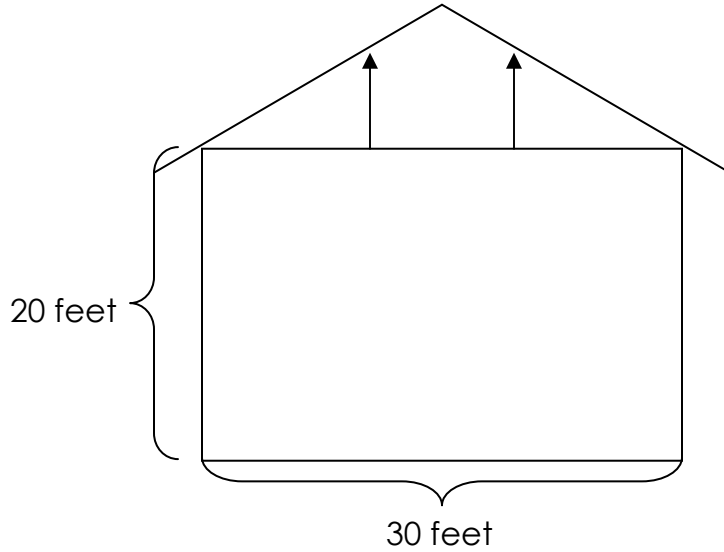

Two roof supports (indicated by the arrows in the drawing) need to be placed 6 feet from the center line of the building. Ignoring the thickness of these supports, how long should they be? Show work that supports your answer.

_____ feet

Performance Event

PE-01

G1B9

A fast food restaurant recently gave toys away in its children's meals. The toys came inside a cardboard pyramid. Unfolded, the pyramid had this design:

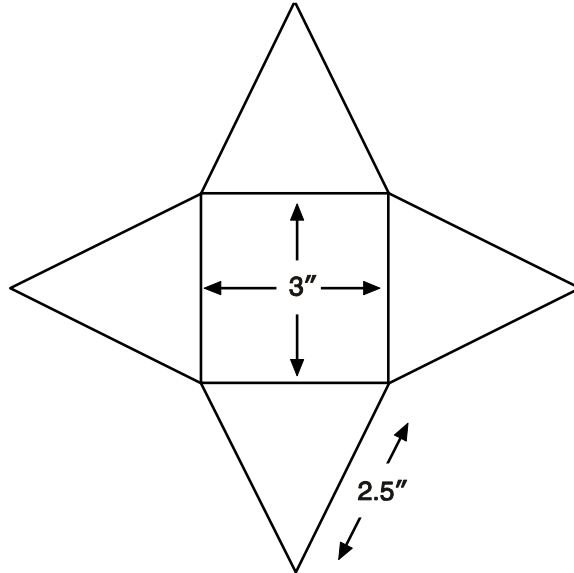

A. Calculate the area of wasted (scrap) material if each pyramid is stamped out of a square piece of cardboard that is 7 inches on each side. Provide the work that shows how you arrived at your answer and write your answer on the line.

Area: _____ sq. inches

B. Can the amount of scrap material be reduced? If so, write a letter to the president of the fast food restaurant company explaining how it can save money on the production of these cardboard pyramids by determining the amount of scrap material saved. Include drawings if you wish. If the amount of scrap material cannot be reduced, explain why.

Write your letter to the president of the fast food restaurant here.