

Mathematics, Grade 4**A2A4**

Which number sentence shows how 7 students could share 35 pieces of candy so that each student gets the same number of pieces?

A. $7 + 35 = \underline{\quad}$

B. $35 - 7 = \underline{\quad}$

C. $35 \div 7 = \underline{\quad}$

D. $35 \times 7 = \underline{\quad}$

A1B4

Which number below is the missing number in this table?

In Number	Out Number
3	24
5	40
7	
9	72

A. 35

B. 49

C. 56

D. 58

A4A4

It takes 3 students a total of 15 minutes to work their math problems and 4 students a total of 20 minutes to work their problems. Which statement describes how long it takes students to work their math problems?

- A. $15 + 20 = 35$
- B. Add 15 each time.
- C. The number of minutes equals 5 plus the number of students.
- D. The number of minutes equals 5 times the number of students.

G1A4

Which of the following represent rectangular prisms?

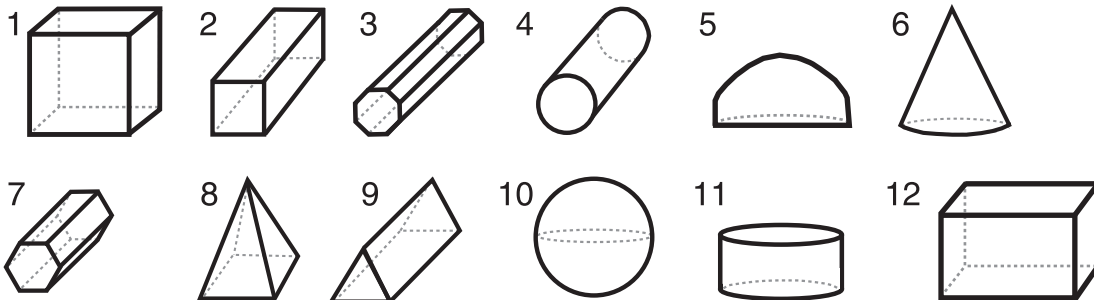

- A. 2, 9, 11
- B. 3, 4, 7
- C. 5, 6, 10
- D. 1, 2, 12

G4A4

Which shape do these prisms have in common as a face?

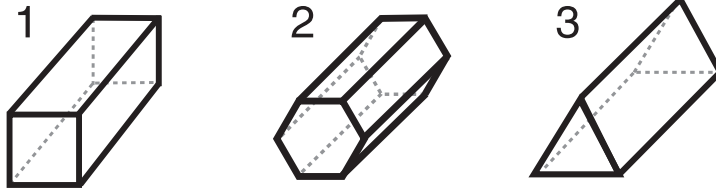

- A. hexagon
- B. triangle
- C. sphere
- D. rectangle

A2B4

Mrs. Stephens' math class is studying the commutative property. She asked students to write a multiplication number sentence to show this property. Which student's number sentence shows the commutative property?

- A. Alice's number sentence: $5 \times 25 = 125$
- B. Tom's number sentence: $5 \times 25 = 25 \times 5$
- C. Alex's number sentence: $125 \div 5 = 25$
- D. Jankeisha's number sentence: $5 \times 25 = 125 \div 5$

A2B4

Which of the examples below shows the commutative property of multiplication?

A. $4 + 5 = 5 + 4$

B. $4 \times 5 = 5 \times 4$

C. $4 + 5 + 5 + 4$

D. $4 \times 5 = 20$

A2A4

Sally has 28 bugs in her bug collection. She collected two of them yesterday. Which number sentence describes the number of bugs she had on the day before yesterday?

A. $28 + 2 = \square$

B. $28 \times 2 = \square$

C. $28 - 2 = \square$

D. $28 \div 2 = \square$

G1A4

Which kind of prism does this figure represent?

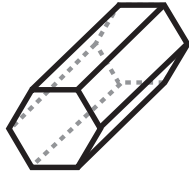

- A. triangular
- B. rectangular
- C. hexagonal
- D. octagonal

A3A4

Sid has 4 purple tiles. He has two times as many purple tiles as orange tiles. He has three times as many green tiles as orange tiles.

How many green tiles does Sid have? In the space below, show how you figured out how many green tiles Sid has.

_____ green tiles

A1A4

On the line, draw the shape that would be next in this pattern.

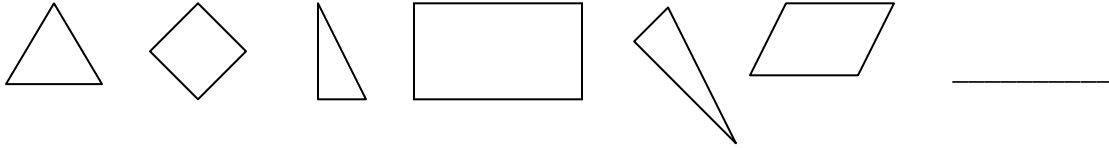

Describe the pattern in words:

G3C4

Draw a polygon with at least two lines of symmetry. Draw two lines of symmetry on the polygon.

A large empty rectangular box for drawing a polygon with at least two lines of symmetry and drawing two lines of symmetry on it.

A1B4

Write the next number in the pattern.

3, 6, 12, 24, 48, _____

Describe this pattern:

G4A4

What are the shapes of the faces on this figure?

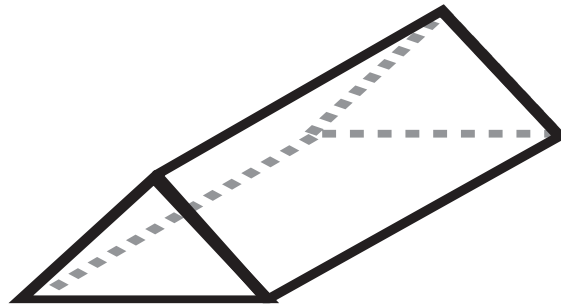

Shapes: _____

A1B4

Manford put some coins in a coin exchange box that was not working properly. Whenever he put a nickel in the box, 11 cents came out. When he put in a penny, 3 cents came out of the box. When he put in a quarter, 51 cents came out.

Complete this In/Out chart that shows what happens when Manford puts the following amounts into the coin exchange box: 10¢, 50¢, \$1.00.

In	Out
1 ¢	3 ¢
5 ¢	11 ¢
25 ¢	51 ¢

Write a sentence that describes what happened to the in number to get the out number.

A3A4

The fourth grade class is sponsoring the Ring Toss at the school fair. Each colored ring that lands on the pole scores the points listed below. With each ticket you get **two of each colored ring** to toss.

Red	Blue	Green	Gold
10 points	15 points	20 points	double previous points earned

Bob's goal is to score 30 points and win a prize. Which rings would he need to land on the pole to score 30 points?

What rings will Bob need to score 30 points?

Rings Bob needs: _____

Write a number sentence to show how you got your answer.

Number sentence: _____

A1B4

Jason is making an arrangement with odd numbers of circles. He begins with one white circle in the Step 1, adds three gray circles in Step 2, adds five white circles in Step 3, and adds seven gray circles in Step 4. He uses a table to keep track of the number of steps and the total number of circles in his arrangement after he adds each step.

Draw the circles in step 5 of Jason's arrangement.

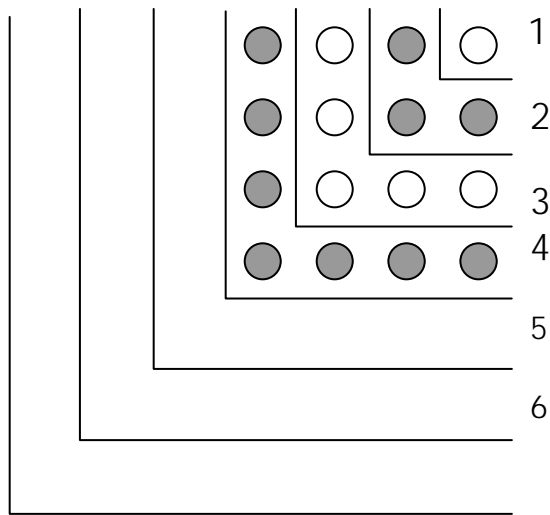

In the box below, tell how you find the **total number of circles** after the 7th step of Jason's arrangement.